



CONTENTS

*Cross-Linked
Polyethylene Foams in
Automotive applications*

The following Technical Information Pamphlet (TIP) examines automotive applications relevant to Cross-linked Polyethylene (XLPE) foams

Introduction

The automotive industry is constantly trying to lower the weight of the average car. Lower weight means improved fuel consumption and better performance. XLPE foams can be found in both commercial and private small vehicles, as well as in large quantities in buses and coaches.

Foam materials are used in under-the-hood, interior and non-interior applications. Some of the parts are quite technical in nature (inasmuch that they might have a multiple task requirement of acoustic and thermal insulation as well as acting as a water seal), whilst other parts have a simple requirement. XLPE foams are problematic for under-the-hood parts due to their heat stability.

Soft trim applications, in doors, dashboards, headliners, seats etc. most often require lamination or adhesion to a PVC or TPO liner and then a subsequent vacuum/thermo forming or compression molding type process to shape into the required part.

Some of the XLPE foam materials used in automotive undergo complex design and heat forming processes, whilst others are just "cut and stuck".

This TIP will give the reader an insight into how and where Palziv foams have found their way into one of the worlds largest industries.

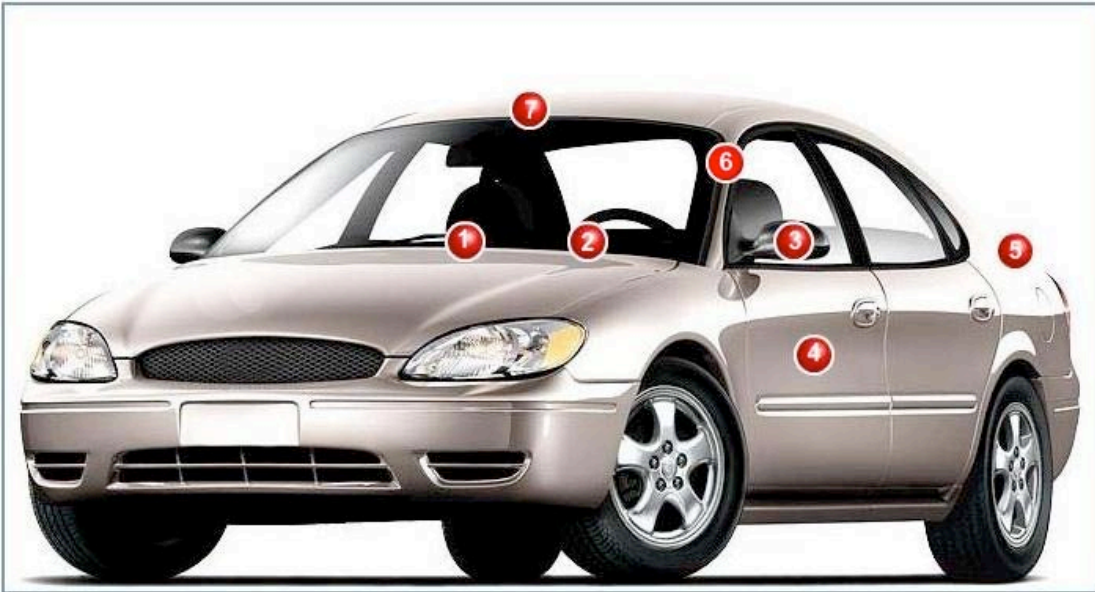

7-Headliner



4 -Door Panel and Water Shields



6 -Seat Liners

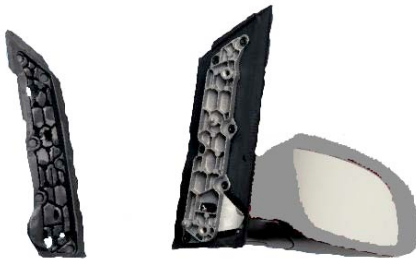

3-Wing mirror seals



2-Dashboard padding



1-Air conditioning ducts



5-Trunk liner

Internal parts

Standards:

The two main requirements when manufacturing parts that are going to be inside the vehicle are:

- 1) Fire Retardancy :Conforming to FMVSS302 (or similar) standard
- 2) Low Fogging values

Motor Vehicle Safety Standard 302 is a fire test requirement for materials installed in motor vehicles. Foams, such as that used in auto head liners, need to pass this test. The MVSS302 test is conducted by placing a sample in the horizontal position in the test chamber. A small flame is started at one end for a prescribed amount of time. In order to pass the test, the flame must not progress beyond a certain length within a specific time frame. The test is classified on a pass/fail basis.(for further details see TIP#1)

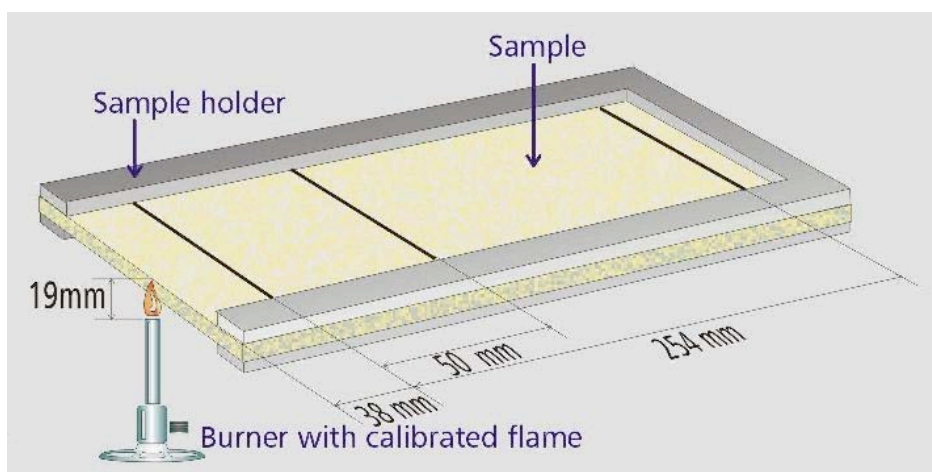

The fogging test is to check that volatiles within the foam are not given out when the material is subjected to high temperatures (such as those found when the car is parked with the doors and windows closed and the sun can heat up the interior to more than 60°C). There are three methods of testing: reflectometric, gravimetric and haze.

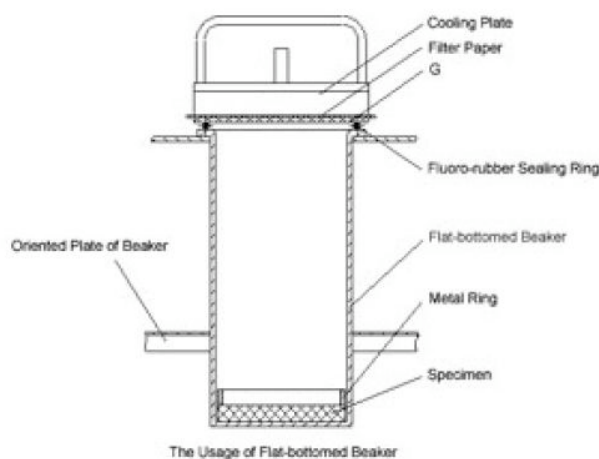

The sample is placed at the bottom of the sealed flat bottomed beaker. For the reflectometric and haze method, a glass plate is used and opaqueness is measured, whereas for the gravimetric method, aluminum foil is used and the condensed material that can be seen as a white haze on the foil is accurately weighed.

On the whole, XLDPE foam has a much lower fogging value than Polyurethane foams and plasticized PVC sheets that are also used in large quantities within the auto interior. Almost every manufacturer has a slightly different way of doing the test. Some of the tests use standard plasticizers for calibrating the equipment, whilst the haze method is calibration free.

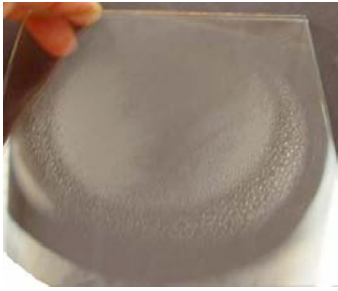

Condensed impurities as seen on a glass sheet. The last thing that a driver wants is an oily haze fogging up the windscreen

All internal parts require testing for fogging. FMVSS302 is only however applicable for non electrical components.

As already mentioned above, the reason for using XLPE foams is due to the lightness and the weight savings that it gives. The foams thermal insulation properties are excellent and in applications such as **Air Condition Ducts** they will completely inhibit condensation (caused by the cold air in the Air Conditioning ducts meeting the hot air of the car). The foam also acts in a role as an acoustic insulator, lowering the intrinsic noise levels of the turbulent air traveling down the tubes. Finally, the flexibility of the foam tubes disposes of the squeaking often found in rigid Polypropylene ducts.

Seat Backs and **Liners** also use XLPE foam. The foam rolls are thermoformed and cut and subsequently attached to the seats.



XLPE foam roll fed into the thermoforming machine from the rear



The foam roll is then heated and formed on the male mold



The XLPE foam is inserted into the seat frame



The parts are removed from the mold

A similar process is undergone for parts such as **Door Panels** and **Water Shields**. Often with these materials, a lamination of a further component such as an adhesive or coating occurs prior to the thermoforming process.

Non-Interior Parts

Non-Interior parts that use XLPE foam are **Wing Mirror Seals and Gaskets**, **Wheelhouse Covers** and **Trunk Liners**.

By far the most interesting and complex are the **Wing Mirror Gaskets**.



The mold



The heat press equipment



"The finished article".
A gasket that seals the mirror from moisture insulates the small mirror motor and stops rattling of plastic and metal components.

Bus and Coach Insulation

In hot (and cold) climates, it is critical that the insulation on public transport vehicles is good. Large air conditioning/heating units are attached to the vehicles, but only work if the vehicle is well insulated.



The main reason for using XLPE foam is for the thermal properties. The added benefit comes from the Acoustic properties that are gained. Previously, Polystyrene foam was the standard for this application, but the brittleness of the foam and the nature of the vibrations and jolting of the standard buses movement, destroyed the foam insulation and what remained was a powder. The toughness and resilience of the XLPE foam, coupled with its chemical resistance (suitable for contact with oils, greases and solvents), as well as its water resistance, meant that it is the ideal replacement material for this application.

As can be seen, the side walls of a bus insulated with XLPE foam. (Below, the roof can be seen). The thermal and acoustic insulation properties are beneficial for passenger comfort and for reducing energy consumption



Even with the current financial crisis around the world, the automotive industry is still greatly in need of XLPE foam. Over the coming years, more and more metal replacing applications will use plastics and particularly foams to save weight, and with it energy, as well as improving the insulation (both thermal and acoustic) properties.

USA & Canada

Palziv North America 7966 NC 56 Hwy Louisburg, NC 27549

E-mail: Info@palziv.com